



NorthStar ALD System

- The NorthStar Atomic Layer Deposition (ALD) system is a versatile research deposition tool for thermal or energy enhanced ALD
- With up to 8 precursor lines and a hot wall deposition chamber, a wide range of applications may be performed by a single system
- Sample introduction is rapid and convenient with a quick hatch or the optional load lock
- The NorthStar ALD system can be interfaced with other deposition and metrology tools
- Integration of in-situ metrology tools and the RoboALD™ software/system automation increases process reproducibility
- Fully UHV Upgradeable
- Demo and deposition services available

SVT Associates, Inc.

- Leading manufacturer of thin film deposition equipment since 1990
- In-house laboratory for materials research and process development
- Established a diverse range of deposition components, systems, integrated sensors, and process control
- Developed strong combination of equipment manufacturing and process know-how
- Seven Applications Laboratory deposition systems producing world class materials
- Diverse system product line spanning the thin film deposition market
- Leading supplier with over 120 systems in the field

Applications

- High-k Dielectrics
- Nanocoatings
- MEMS
- Photonic Crystals
- Diffusion Barriers
- Device Encapsulations
- Surface Modification Layers



Specifications Model ALD-P-200B

ALD REACTOR MODULE

Reactor Chamber Up to 8" (200 mm) Wafer Capacity (Optional 300 mm)
 Hot Wall Chamber Design – Temperature Controlled (UHV Compatible version available)
 Three Gas Inlet Injection Ports
 (Two for Precursor Manifolds and One for Gas Inlet)
 Close Coupled Sample Heater to 500 C
 Load Lock Flange, Pumping Port
 Provision for Quartz Crystal Monitoring and RGA

Reactor Pumping Dual Stage Rotary Vane Pump – 7 cfm (200 l/min)
 Heated Pumping Line Isolated with Valve
 (Optional Hot trap, Particle Filter, and Cold Trap in Pumping Line)
 Other Pumping Options Available

Base Pressure <1 x 10⁻³ Torr or better

Vacuum Gauge Convectron® Gauge

Electronics Control Electronics
 Sample Heater Power Supply and Controller
 Chamber walls Heater Power Supply, Thermocouple and Temperature Controller
 Gas Line Heater Power Supply, Thermocouple and Temperature Controller

ALD Console Clean Room Compatible Metal Enclosure

PRECURSOR MANIFOLD(S)

Carrier Gas Line One for Each Manifold (Typically N₂)
 Mass Flow Control

Precursor Admission Precursor sources from Liquid, Solid, or Gas phase
 Heated Precursor Manifolds with up to 4 Precursors
 Each (Option for second Manifold for up to 8 Precursors)
 Fast ALD High Temp Valves (15 msec)
 Metal VCR® fittings
 Gas Line Heating to 200 °C

PROCESS CONTROL

Robo-ALD™ Software and Firmware – PLC
 Based on NI LabVIEW® platform
 Recipe Entry and Operation Loops
 Logging of parameters – T, P, Flow, (Optional RGA)
 Log files can be exported to Excel®
 Automated pumpdown / vent to atmosphere

Deposition Uniformity
 < ± 1 % over 200 mm – Reference – Al₂O₃, thickness > 20 nm

Deposition Mode Standard, or “soak” mode for high aspect ratio samples

LOAD LOCK (OPTIONAL)

Load Lock Chamber Sizes available up to 300 mm Wafer Capacity
 Manual Gate Valve

Safety Software safety interlocks
 Smoke detector in cabinet
 Low voltage Emergency Off (EMO)
 Single point power connection

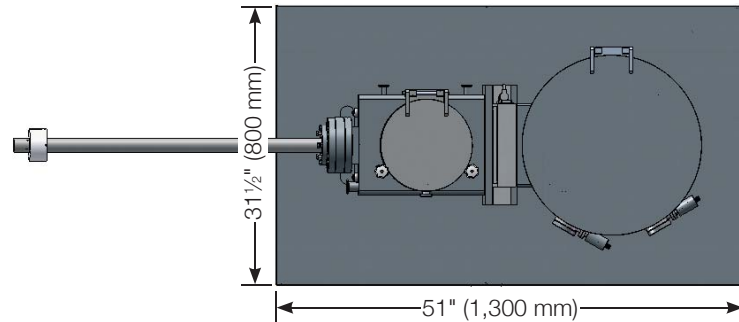

EXTERNAL SERVICES

Electrical Service 220/380 VAC, 50A, Single or Three Phase, 50-60 Hz

COMPRESSED AIR/N₂/Ar

Valve Manifold 75 PSI CDA at 0.1 cfm (500 kPa at 2.8 liter/min)
 pressure regulated
 Relative humidity < 20% Dry N₂ may be substituted

Carrier Gas 5 PSI (35 kPa) Research Grade N₂ or Ar
 Also used to vent reactor

Exhaust Vacuum pump and Cabinet

COOLING WATER

Reactor Chamber 2 l/minute at approx. 20 °C, or a water chiller when inner chamber wall is run >150 °C

