

# In-Situ Cathodoluminescence



## Description

The In-Situ CL system is an ideal solution for the monitoring of thin film growth during MBE processes. Mounted in a single viewport SVT Associates CL system provides accurate, real-time information on substrate composition and optical quality using a standard RHEED gun (e.g. SVT Associates RHEED Gun) in combination with a sensitive optical detection system. Retracting the system up to eight inches ensures minimum interference during growth. The electron excitation technique allows depth profiling by adjusting the electron energy. A windows based software package allows fully automated processing and analysis of the spectra.

## Specifications

Spectral Range	200 – 900 nm
Resolution	0.5 nm
Detector Quantum Efficiency	25%
Detector Output	10 V/nW
Equivalent Noise	250 V
Viewport	2.75" CF
External Dimensions	9.0" x 25.5" x 10.1" (22 cm x 65 cm x 26 cm)
In Vacuum Length	1.25" x 13.1" (3.2 cm x 34 cm)
Travel Distance	Up to 8" (20.3 cm)
Target Distance	2" (5.1 cm)
Computer Requirements	Windows 9x, 2000, XP

## Features

- Measurement of Film Composition and Optical Quality on a Single Viewport
- Information of Doping Levels
- Retractable System for Minimum Interference
- Description Fully Computer Controlled Acquisition and Analysis

Models	Description
CL-0-2.75	Base In-Situ CL Instrument
CL-0-F	Fiber Based In-Situ CL System for Minimum Optical Access
RH-CBL	Cable Set
CL-4-6	In-Situ CL System 6" Mounting Flange Optional Ports for Pyrometer

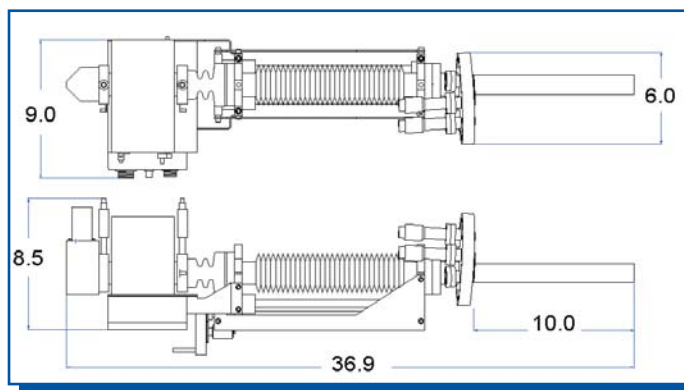

All Dimensions In Inches

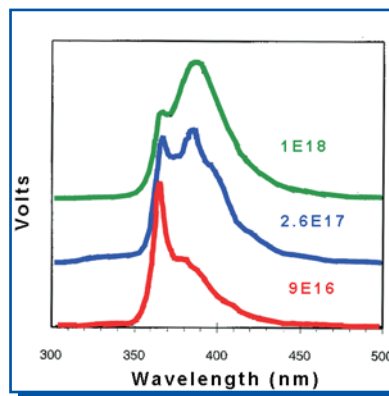

In-Situ CL Spectrum from several Mg doped p-type GaN films on sapphire. Measured hall carrier concentration is given for each curve. (Appl. Note 1101)

